

Серия / Series / Série **A**
Ø 9,5 mm – 11,07 mm

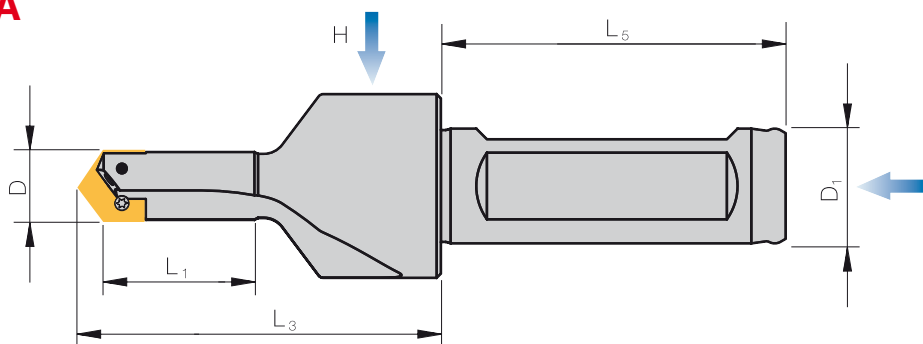
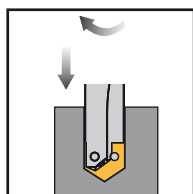

с внутренним подводом СОЖ
with through tool coolant
avec arrosage interne

Корпуса серии / Holders series / Forets série **A**

Обозначение Designation Désignation	Длина Length Longueur	D	L ₁	L ₃	D ₁	L ₅	H	MK
HA950-1107-19GW16	1,5-2 x D Extra short Extra court	9,5 - 11,07	19	50,0	16	41,9	1/8"	—
HA950-1107-32GW20	3 - 4 x D Short Court	9,5 - 11,07	32	63,5	20	41,9	—	—

Резьбовое отверстие - G1/8 / Grub screw / Vis de serrage 20906-G1/8

Серия / Series / Série **A**
Ø 9,5 mm – 11,07 mm

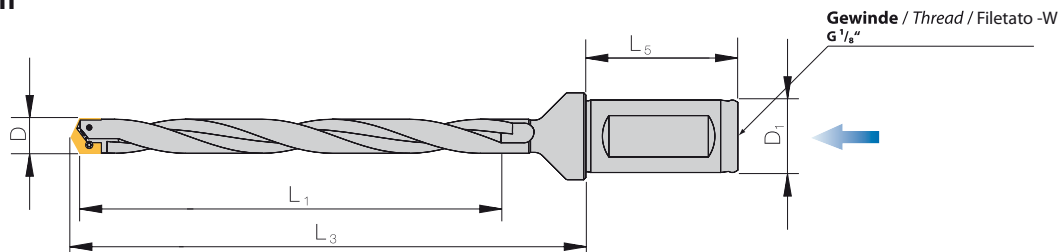
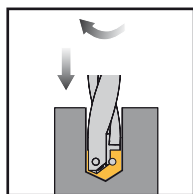

с внутренним подводом СОЖ
with through tool coolant
avec arrosage interne

Корпуса серии / Holders series / Forets série **A**

Обозначение Designation Désignation	Длина Length Longueur	D	L ₁	L ₃	D ₁	L ₅	H	MK
HA950-1107-60SPW20	7 - 8 x D Standard Standard	9,5 - 11,07	60,0	91,1	20	41,9	—	—
HA950-1107-111SPW20	8 - 12 x D Extended Long	9,5 - 11,07	111,0	142,9	20	41,9	—	—
HA950-1107-111SPW20-W	8 - 12 x D Extended Long	9,5 - 11,07	111,0	142,9	20	41,9	—	G 1/8"

Внимание: Смотрите варианты применения на странице 80!

Remark: Please see the application guidelines for this holder on page 83!

Attention: Pour ces outils, voir les données d'application en page 85!