

LAB

Abstechplatten mit 0° Spanwinkel

- für Automatenstähle und legierte Stähle
- zum Abstechen kleiner Durchmesser
- einfach nachschleifbar
- auf allen Haltern einsetzbar

Part-off insert with 0° chip breaker

- for steel and alloyed steel
- for parting off small diameters
- easy to re-grind
- can be used on all holders

Отрезные пластины с передним углом 0°

- для стали и легированной стали
- для отрезки малых диаметров
- легкая переточка
- используются на державках всех типов

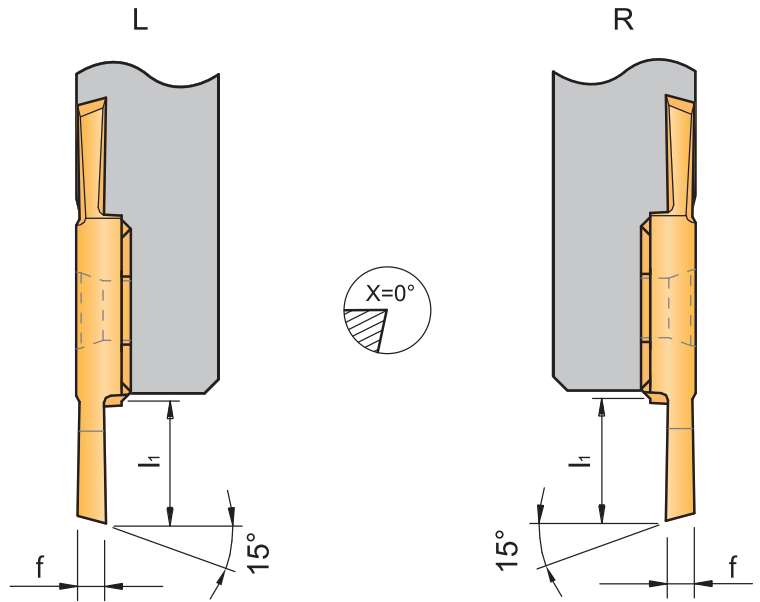

Schneideinsätze / Inserts / Пластины

Bezeichnung Designation Обозначение	f	l ₁	Sorten / Grades / Сплавы		
			AP4020	AP5020	AK1020
LAB 080804FL	0,8	4,0	●	●	●
LAB 080804FR	0,8	4,0	●	●	●
LAB 081005FL	1,0	5,0	●	●	●
LAB 081005FR	1,0	5,0	●	●	●
LAB 081205FL	1,2	5,0	●	●	●
LAB 081205FR	1,2	5,0	●	●	●
LAB 081507FL	1,5	7,0	●	●	●
LAB 081507FR	1,5	7,0	●	●	●
LAB 082085FL	2,0	8,5	●	●	●
LAB 082085FR	2,0	8,5	●	●	●
LAB 082585FL	2,5	8,5	●	●	●
LAB 082585FR	2,5	8,5	●	●	●

● Hauptanwendung
Main application
Основное применение

○ Nebenanwendung
Secondary application
Вторичное применение

	P	M	K	N	S	H
AP4020	○	●				
AP5020		●				
AK1020				●	●	