

LST

Stechdrehplatte mit 0° Spanwinkel

- zum Einstecken und Stechdrehen von kleinen Werkstückdurchmessern

Groove and turn insert with 0° chip breaker

- for grooving and turning of small diameter components

Обработка канавок и копировальное точение. Передний угол 0°

- для обработки канавок и копировального точения малых диаметров

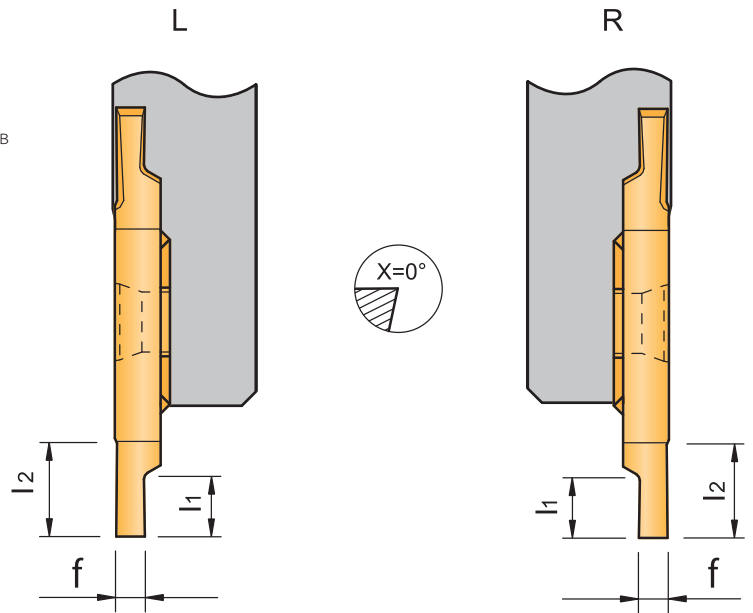
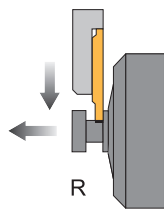

Schneideinsätze / Inserts / Пластины

Bezeichnung Designation Обозначение	f	l ₁	l ₂	Sorten / Grades / Сплавы		
				AP4020	AP5020	AK1020
LST 080802FL	0,8	2,0	4,0	●	●	●
LST 080802FR	0,8	2,0	4,0	●	●	●
LST 081025FL	1,0	2,5	4,0	●	●	●
LST 081025FR	1,0	2,5	4,0	●	●	●
LST 081230FL	1,2	3,0	4,0	●	●	●
LST 081230FR	1,2	3,0	4,0	●	●	●
LST 081530FL	1,5	3,0	4,0	●	●	●
LST 081530FR	1,5	3,0	4,0	●	●	●
LST 082040FL	2,0	4,0	6,5	●	●	●
LST 082040FR	2,0	4,0	6,5	●	●	●
LST 082560FL	2,5	6,0	6,5	●	●	●
LST 082560FR	2,5	6,0	6,5	●	●	●
LST 083065FL	3,0	6,5	6,5	●	●	●
LST 083065FR	3,0	6,5	6,5	●	●	●

- Hauptanwendung
Main application
Основное применение
- Nebenanwendung
Secondary application
Вторичное применение

P	○	●	
M		●	
K			
N	●		●
S		●	●
H			

4