

LVD

Drehplatte mit 0° Spanwinkel

- zum Drehen kleiner Durchmesser
- wahlweise mit 90° oder 92° Einstellwinkel

Turning insert with 0° chip breaker

- for turning small diameters
- optional 90° or 92° approach angle

Точение. Передний угол 0°

- для точения малых диаметров
- угол в плане 90° или 92°

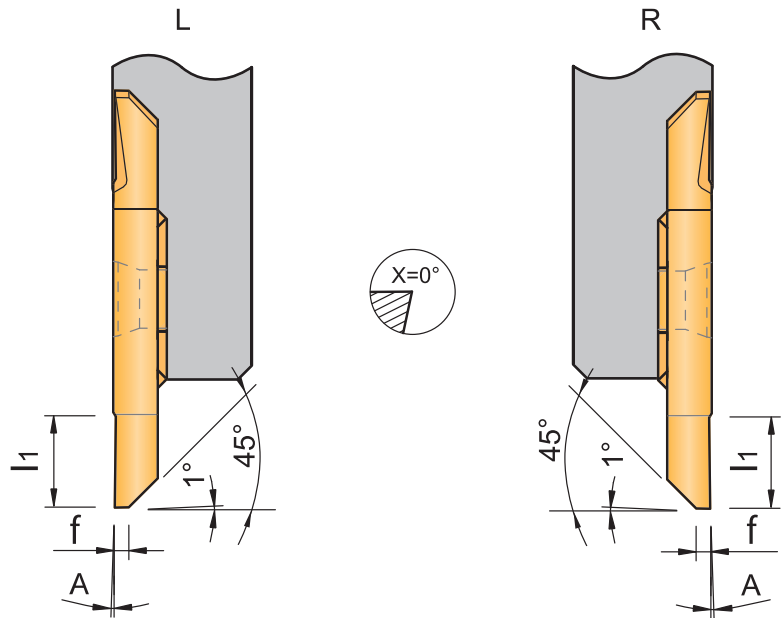
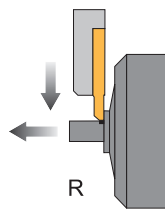

Schneideinsätze / Inserts / Пластины

Bezeichnung Designation Обозначение	f	l ₁	A	Sorten / Grades / Сплавы		
				AP4020	AP5020	AK1020
LVD 08-0FL	1,0	6,5	0°	●	●	●
LVD 08-0FR	1,0	6,5	0°	●	●	●
LVD 08-2FL	1,0	6,5	2°	●	●	●
LVD 08-2FR	1,0	6,5	2°	●	●	●

- **Hauptanwendung**
Main application
Основное применение
- **Nebenanwendung**
Secondary application
Вторичное применение

	P	M	K	N	S	H
● Hauptanwendung	○	●				
○ Nebenanwendung			●			
				●		●
					●	●

4